

VARIPLEX™

Three-Way Screen System

- THX® approved¹
- Patented high-frequency system
- Vari-Intense Technology for smooth, even coverage
- Compact design for limited behind-the-screen space
- Ring-Mode Decoupling (RMD™) provides greater intelligibility
- Digital Dynamics Capable™
- Factory pre-assembled mid/high unit

Description

The Electro-Voice Variplex™ is designed specifically for use in ultrahigh-fidelity cinema applications. The system is THX®-approved¹ and offers Electro-Voice patented technology. The Variplex™ is a three-way configuration that addresses many performance issues not addressed in other three-way designs. The Variplex™ employs Electro-Voice's patented² Vari Intense® (VI) variable-intensity horn system. This design offers two fundamental advantages. The variable horn throat impedance provides uniform sound pressure levels over the entire auditorium. Conventional horn systems attempt to do the same by aiming the center of the high-frequency/mid-frequency horn toward the rear of the room. This conventional approach wastes fully one-half of the system energy and headroom, and radiates wasted energy onto the ceiling and walls, thus producing reflections that further degrade overall intelligibility and system clarity. The patented variable-intensity approach, on the

other hand, compensates for the natural phenomenon of sound reduction with distance and produces extremely uniform coverage for the entire seating area. The same level of fidelity in the front, middle and the back of the room is achieved while substantially reducing reflected energy and consequently greatly improving tonal quality and intelligibility. The advantages are twice the headroom and greatly improved fidelity.

The Variplex™ is also unique in that its three-way design utilizes a bass/mid-bass/high-frequency approach rather than a conventional bass mid-range/high-frequency design. This mid-bass/high-frequency approach produces superior vocal clarity. Also incorporated into the Variplex™ is Electro-Voice's Ring-Mode Decoupling (RMD™). Ring-Mode Decoupling employs mechanical and acoustical equalization to resolve system resonances (or ringing modes) and frees electrical equalizers to perform the job they were originally intended to perform, that being room equalization and correction of the spectral characteristics inherent in the transducers themselves. Prior designs have frequently attempted to "resolve" loud-

speaker design issues with electrical equalizers. RMD™ substantially improves system transient detail and further refines system clarity.

The compact design of the Variplex™ allows the system to be used even when behind-the-screen space is limited. Compact design can also provide a cost savings by allowing the addition of extra seating.

The unique performance enhancements and system capabilities are ideally suited to the high dynamic-range demands of digital material. When the Variplex™ is used in conjunction with Electro-Voice's THX®-approved subwoofers, the combination defines a new standard for realism and total system accuracy.

Mounting Instructions

Refer to Figures 1 and 2 for the following steps.

1. Remove five screws on top of the TL606DMT (see figure 2), the two farthest from the front of the enclosure are 1 3/4" and will be needed be replaced in the same holes.

¹ The Variplex™ is THX-approved for screen to last row distances up to 80 feet. THX is a registered trademark of Lucasfilm Ltd.

² U.S. Patent 5,020,630, Loudspeakers & Horn Therefor.

VARIPLEX™

2. Set the mid/high subassembly on top of the TL606DMT align the empty holes on the TL606DMT with the three slots and center pivot hole of the mid/high subassembly mounting board. Reinstall the screws previously removed, being sure to install the longer two screws in the back slot under the adjustment bracket.
3. Adjust the horizontal position and securely tighten all the bolts so that the mid/high subassembly can not inadvertently rotate.
4. Now loosen the two vertical adjustment bolts just enough so the adjustment guides will slide within the adjustment slot. Adjust the vertical angle, by tilting the mid/high subassembly, which will slide the adjustment bolts along the slot as shown in figure 1.
5. The aiming point of the mid/high subassembly horn separates the mid-frequency section from the high-frequency section, (see figure 1). For proper imaging, this point should be positioned just above the vertical center line of the screen (typically 0.6 of the overall screen height), (see figure 2). Then tilt vertically to align with the head of the person in the last seat of the theater, (See figure 2), and tighten the vertical adjustment bolts, so the mid/high subassembly can not inadvertently tilt backwards.

(see Crossover Equalization section). The measurement was made with a swept sine-wave signal, 4 volts at 500 Hz, in an anechoic (echo free) environment. The microphone was at a distance of 3.0 m (10 ft), on an axis with the aiming point of the mid/high-frequency unit. Figure 4 shows the frequency response of the individual sections of the Variplex™, measured under the same conditions but with a 4-volt input constant with frequency, the results of which were then normalized to 1 watt/1 meter.

Frequency Response

Figure 4 shows the Variplex™ frequency response with presets using the Electro-Voice Dx34A digital speaker system processor

Crossover/Equalization

To optimize the performance of the Variplex™ the Electro-Voice Dx34A digital speaker system processor may be used. Contact Electro-Voice for information on specific Dx34A presets.

Figure 1— Mounting the HPK-Variplex™ (pre-assembled mid/high unit)

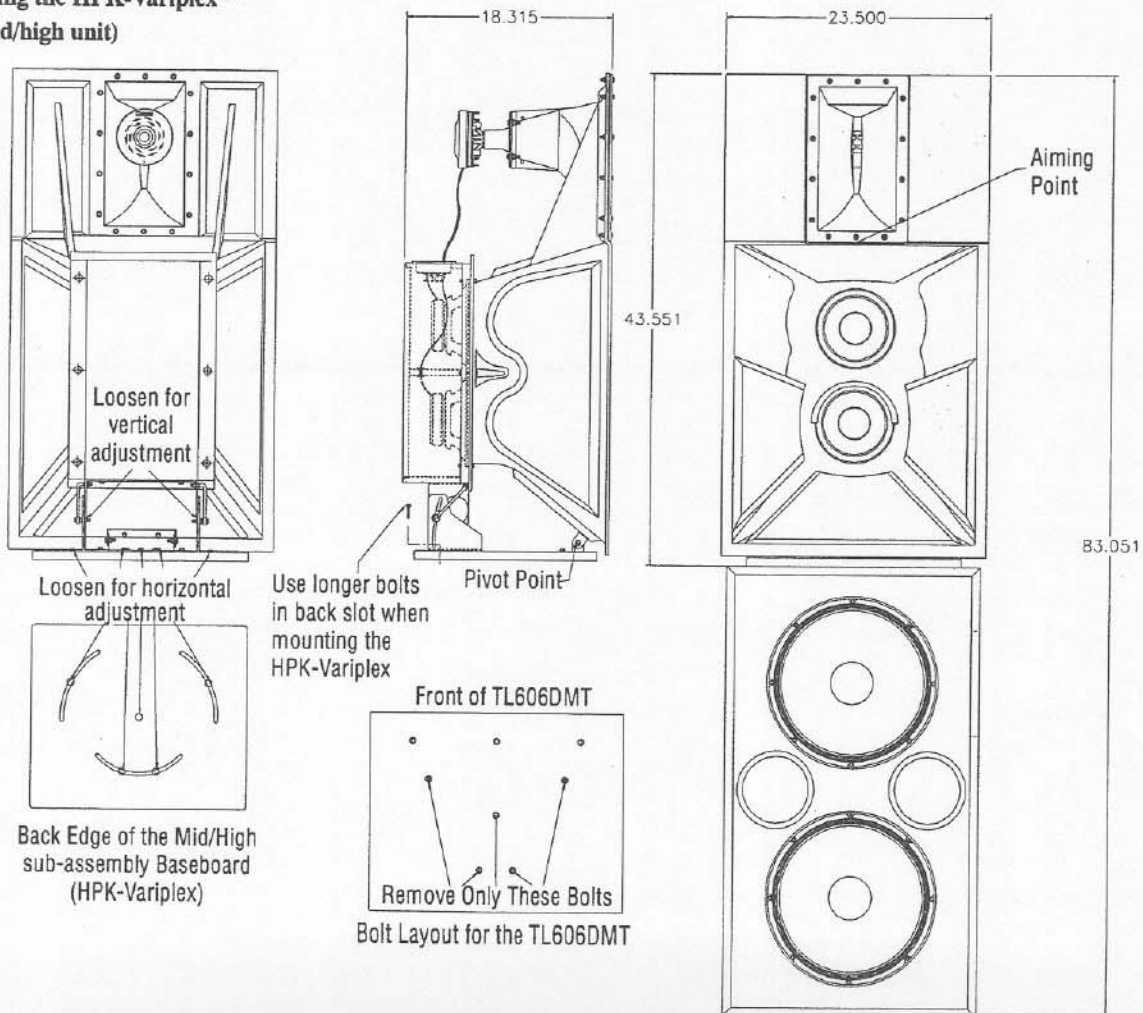

Figure 2—Aiming the Variplex™

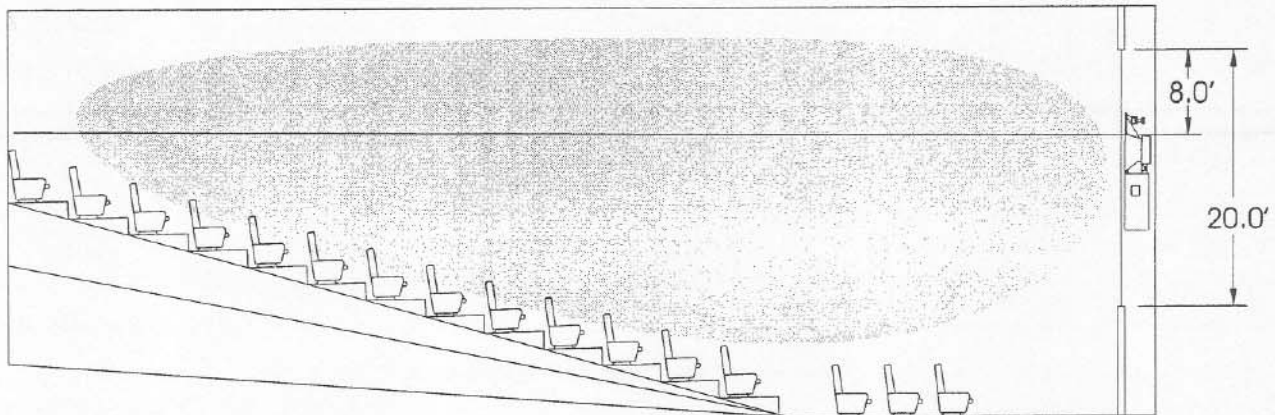

Figure 3—Variplex™ Typical Frequency Response of Low / Mid- and High-Frequency Sections Alone (swept sine-wave input, anechoic environment; normalized response, from 4 volts at 500 Hz at 10 ft., with the microphone axis coincident with the aiming point, midway between mid- and high-frequency horn).

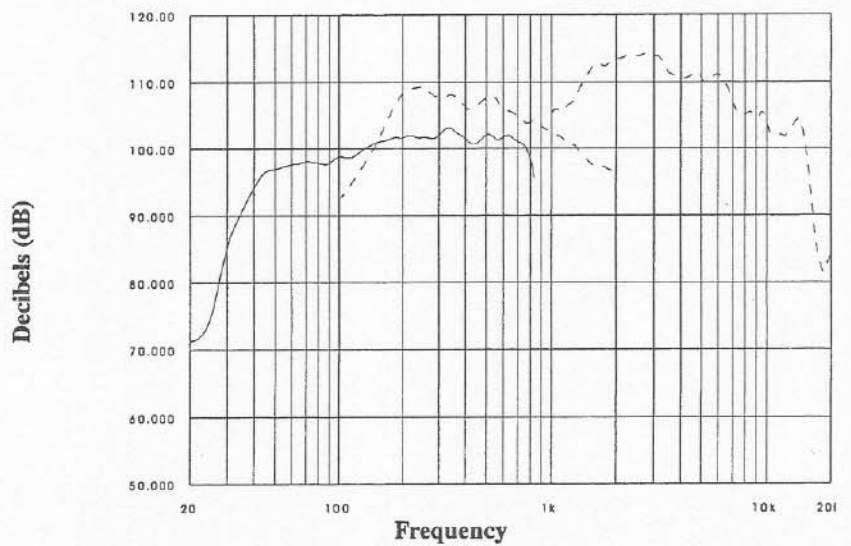
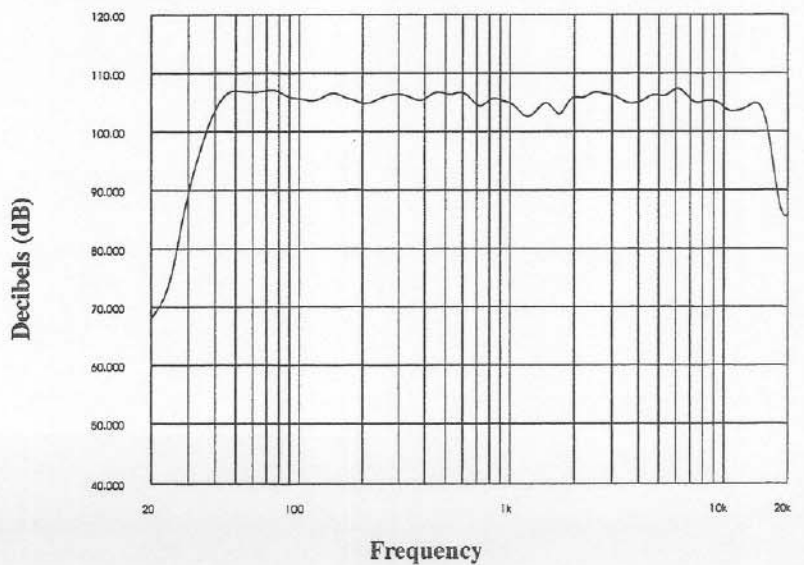

Figure 4—Variplex™ Typical Frequency Response with DX34A Digital Speaker System Processor Presets (swept sine-wave input, under anechoic environment; normalized response, from 4 volts at 500 Hz at 10 ft., with the microphone axis coincident with the aiming point, midway between mid- and high-frequency horn).



Uniform Limited Warranty Statement

Electro-Voice products are guaranteed against malfunction due to defects in materials or workmanship for a specified period, as noted in the individual product-line statement(s) below, or in the individual product data sheet or owner's manual, beginning with the date of original purchase. If such malfunction occurs during the specified period, the product will be repaired or replaced (at our option) without charge. The product will be returned to the customer prepaid.

Exclusions and Limitations: The Limited Warranty does not apply to: (a) exterior finish or appearance; (b) certain specific items described in the individual product-

line statement(s) below, or in the individual product data sheet or owner's manual; (c) malfunction resulting from use or operation of the product other than as specified in the product data sheet or owner's manual; (d) malfunction resulting from misuse or abuse of the product; or (e) malfunction occurring at any time after repairs have been made to the product by anyone other than Electro-Voice Service or any of its authorized service representatives.

Obtaining Warranty Service: To obtain warranty service, a customer must deliver the product, prepaid, to Electro-Voice Service or any of its authorized service representatives together with proof purchase of the product in the form of a

bill of sale or receipted invoice. A list of authorized service representatives is available from Electro-Voice Service at 600 Cecil Street, Buchanan, MI 49107 (800/234-6831 or FAX 616/695-4743).

Other Rights: This warranty gives you specific legal rights, and you may have other rights which vary from state to state. For warranty repair, service information, or a listing of the repair facilities nearest you, contact the service repair department at: 616/695-6831 or 800/685-2606.

For technical assistance, contact Technical Support at 800/234-6831 or 616/695-6831, M-F, 8:00 a.m. to 5:00p.m. Eastern time. Specifications subject to change without notice.

Specifications

Frequency response (See Figure 4):
40 Hz - 20,000 Hz

Power Handling,

Low Frequency:

800 watts continuous
(3200 watts peak)

Mid Bass:

300 watts continuous
(1200 watts peak)

High Frequency:

60 watts continuous
(240 watts peak)

Nominal Directivity,

Horizontal:

90° short axis/60° long axis

Vertical (from system's geometric axis):

5° up at 6 dB/50° down at -18 dB

System Impedance:

Bass:

4 ohms nominal
4 ohms minimum

Mid Bass:

4 ohms nominal
3.6 ohms minimum

High Frequency:

8 ohms nominal
6.3 ohms minimum

Sound Pressure at 1Watt, 1Meter Input (See Figure 3),

LF (40 Hz to 300 Hz, average):
99 dB

MF (300 Hz to 1,500 Hz, average):
105.8 dB

HF (1,500Hz to 7,000Hz (average):
112 dB

Crossover Frequencies (24-dB-per-octave Linkwitz-Riley),

LF/MF: 330 Hz

MF/HF: 1,560 Hz

High-Pack Mounting Holes:

Five, 1/4-20 bolts, Allowing for smooth horizontal adjustment and secure attachment of the pre-assembled high-pack.

Material,

Low Frequency Enclosure:

Black vinyl-clad particle board

Mid/Hi frequency Horn:

Black fiber glass with a black vinyl dual 8-inch speaker enclosure

Input Connectors:

#10 screw terminals for bass, mid bass and high frequency

Dimensions and Weight, Bass Section,

Height:
(100cm) 39.5 in

Width:
(57.2 cm) 22.5 in.

Depth:
(44.8 cm) 17.62 in.

Net Weight:
(49.0kg) 108 lb

Shipping Weight:
(54.4 kg) 120 lb

Mid Bass/High Frequency Section,

Height:
(109 cm) 42.8 in.

Width:
(59.7 cm) 23.5 in.

Depth:
(46.7 cm) 18.37 in.

Weight:
(29.3 kg) 64.5 lb

Shipping Weight:
(38.0 kg) 84 lb

Total System Dimensions,

Height: (209 cm) 82.3 in.

Width: (59.7 cm) 23.5 in.

Depth: (46.7cm) 18.37 in.

Weight: (78.2 kg) 172.5 lb

Shipping Weight: (92.5 kg) 204 lb

Electro-Voice®

600 Cecil Street, Buchanan, MI 49107
800/234-6831, 616/695-6831, 616/695-1304 Fax
©Telex Communications 1998 • Litho in U.S.A.